

# Intro to Synthetic Biology

---

Week 2 - Design Principles  
July 14, 2019

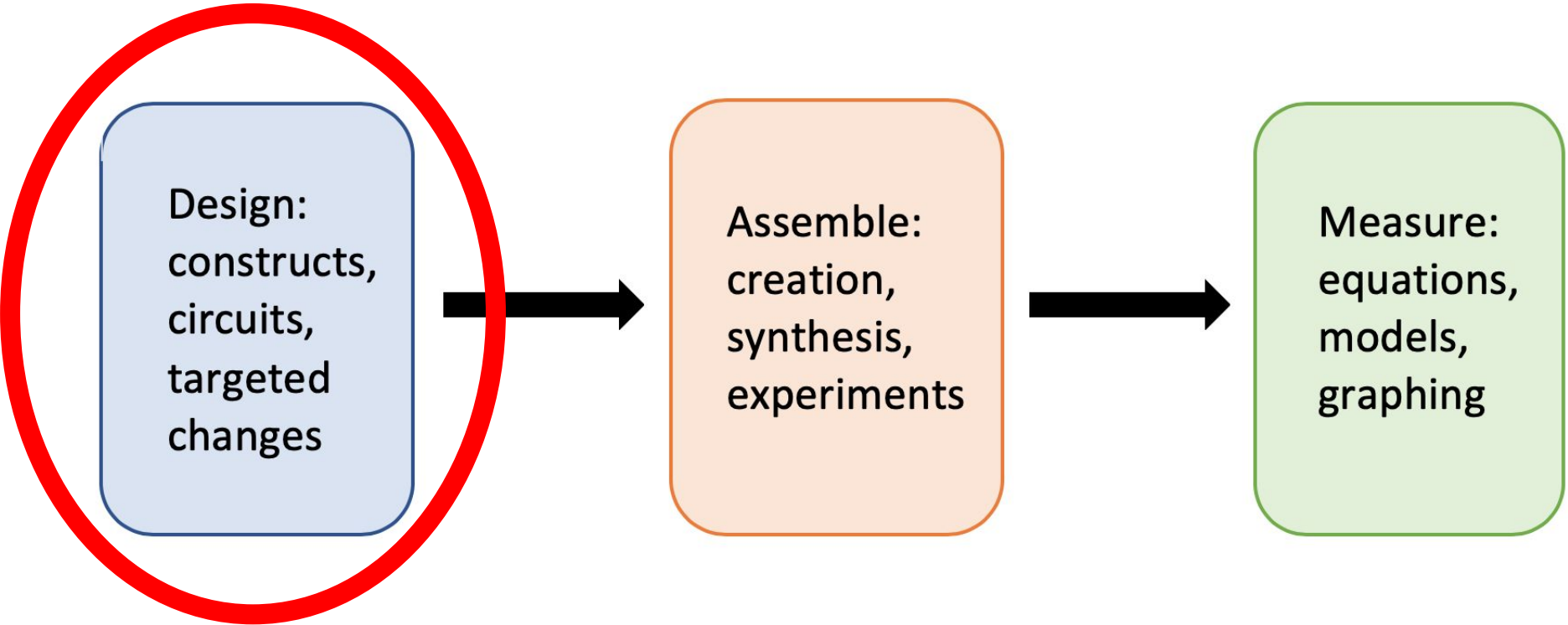

**Design:**  
constructs,  
circuits,  
targeted  
changes

**Assemble:**  
creation,  
synthesis,  
experiments

**Measure:**  
equations,  
models,  
graphing

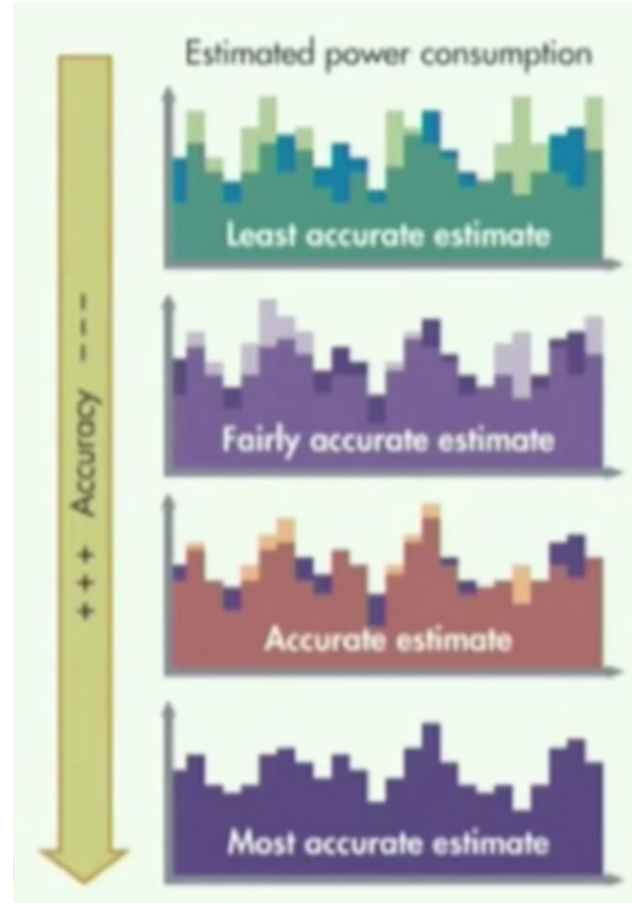
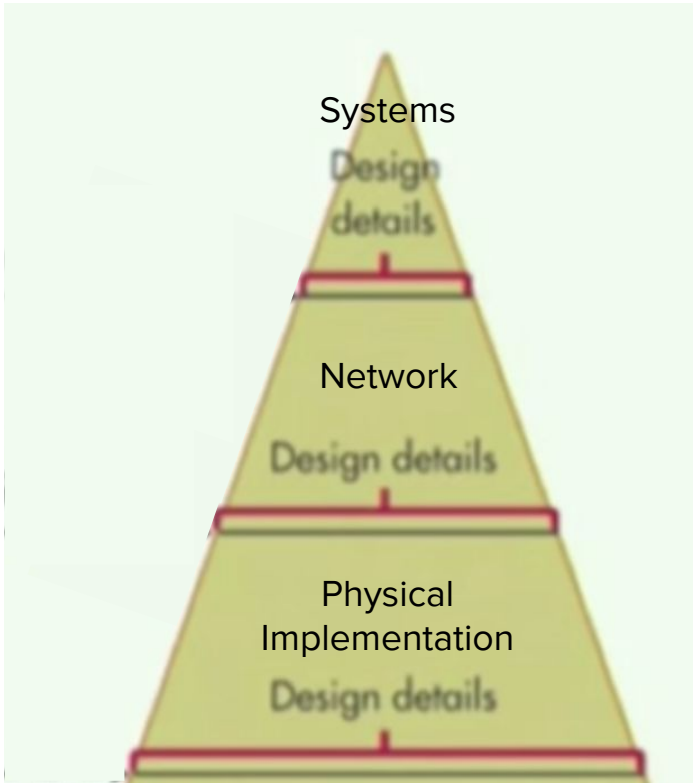

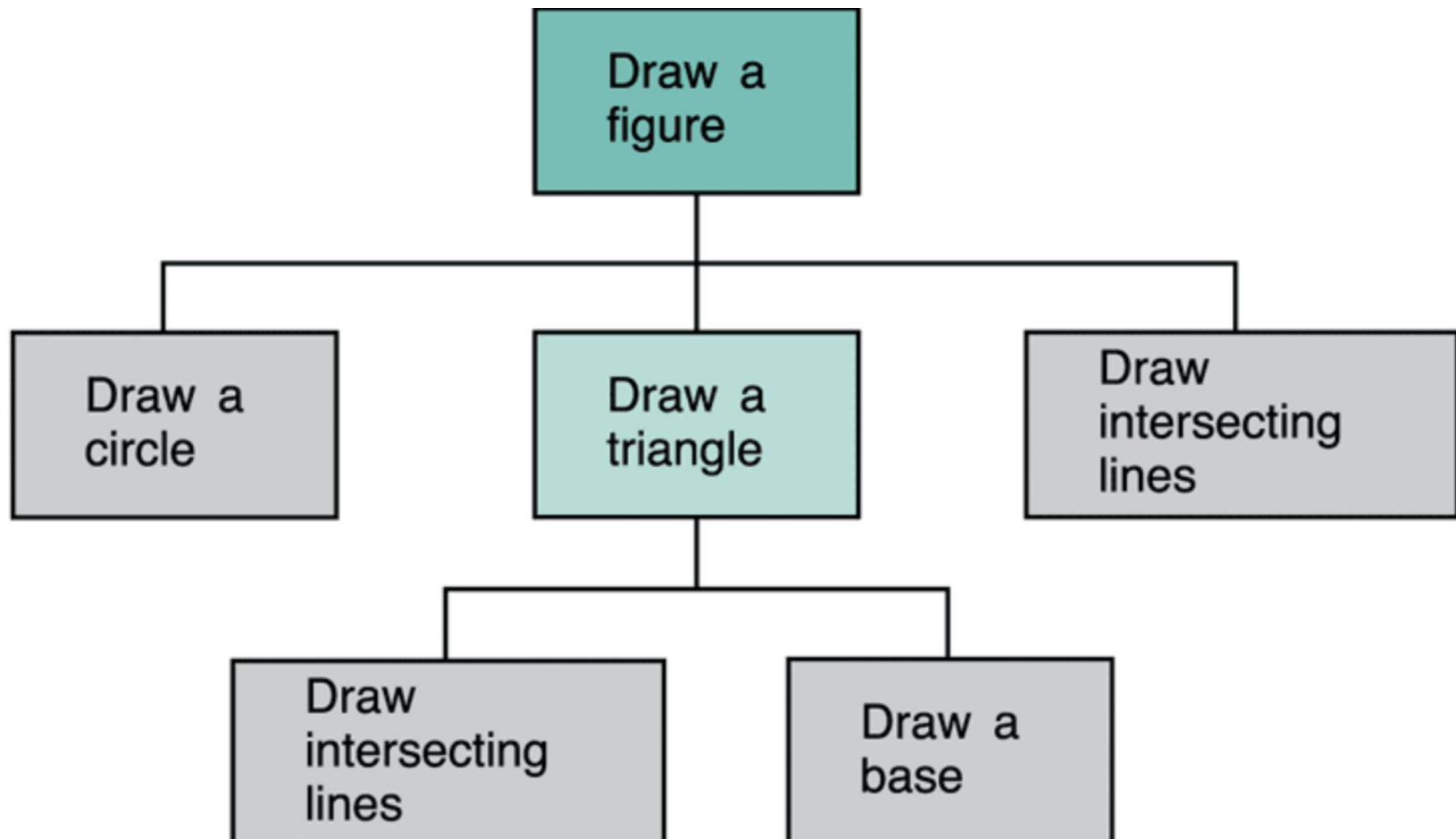

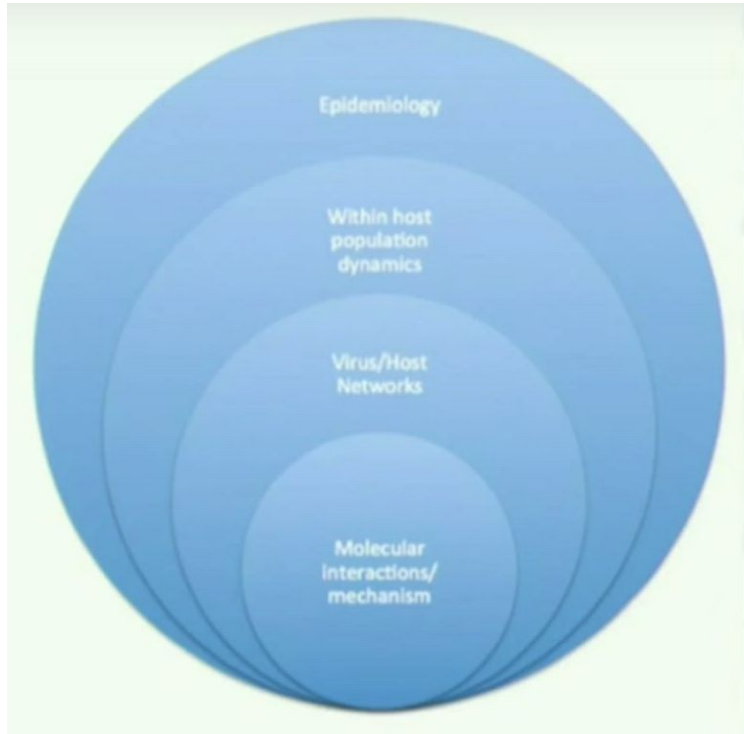

Altered gene spread by **normal inheritance**

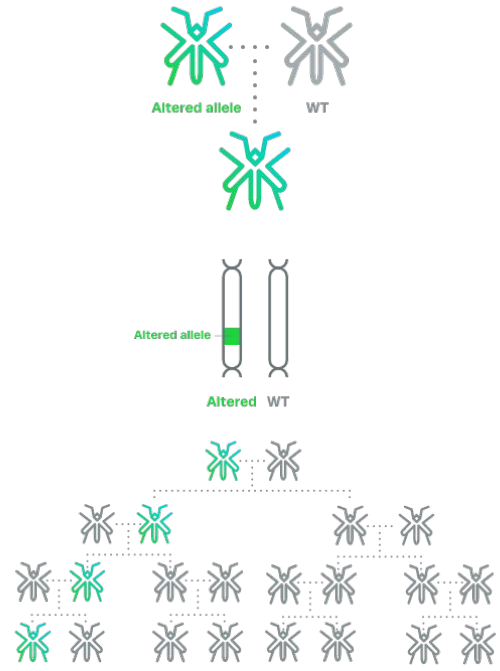

50% chance of passing altered gene via normal inheritance

Altered gene spread by **gene drive**

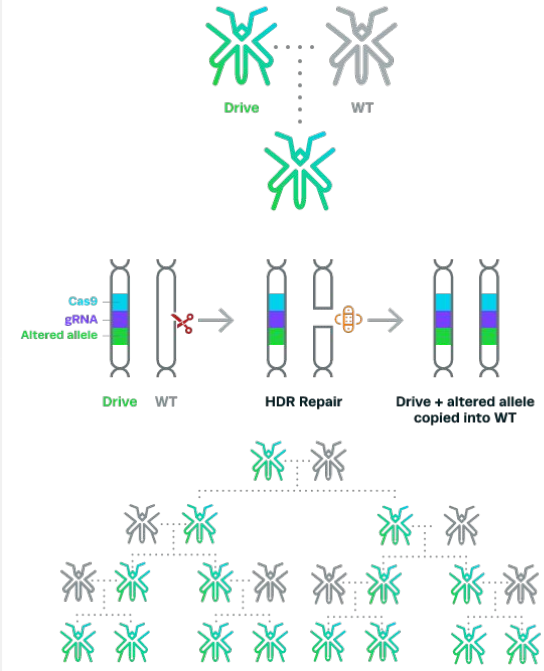

>50% chance of passing altered gene via gene drive

## Inputs

Chemicals

Metal ions

Light

Heat

Nucleic acids

Antigens

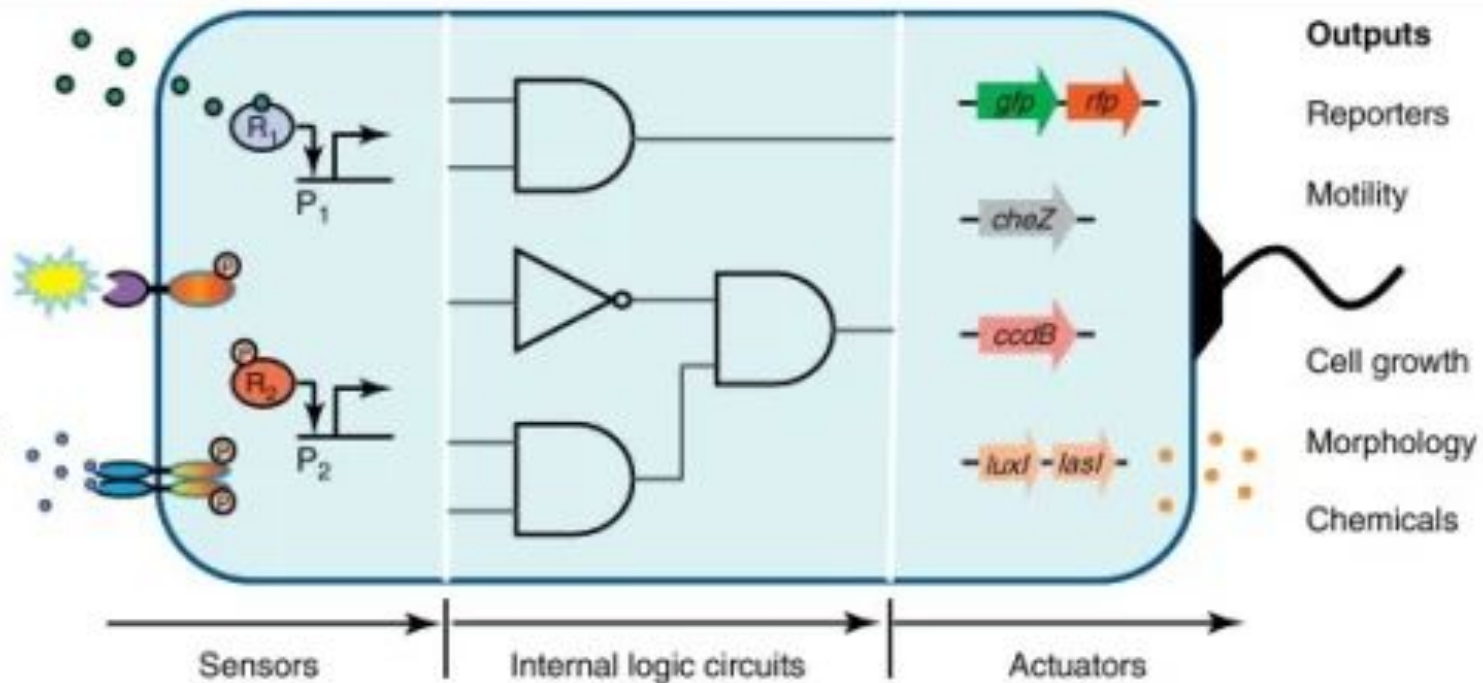



## Regulation

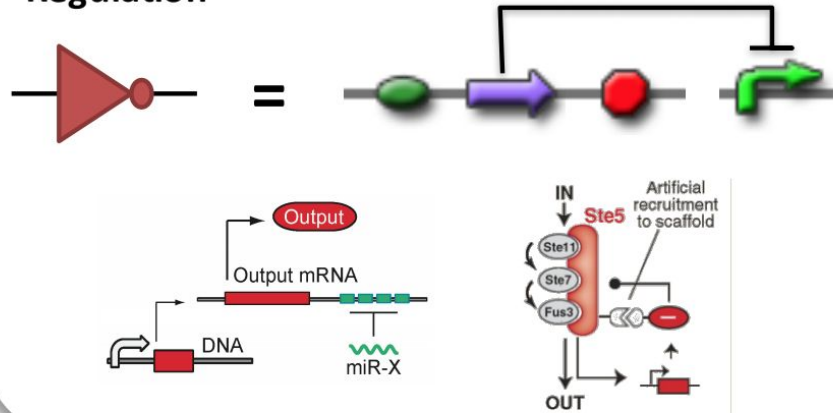

## Cell-cell communication

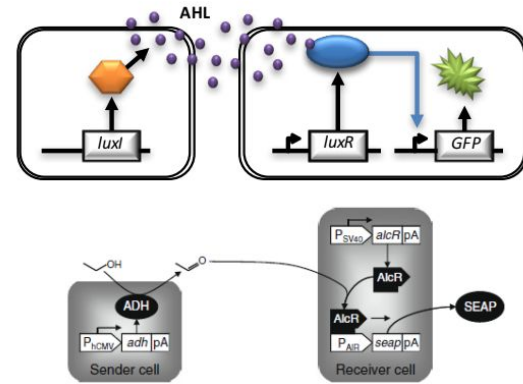

## Reporters

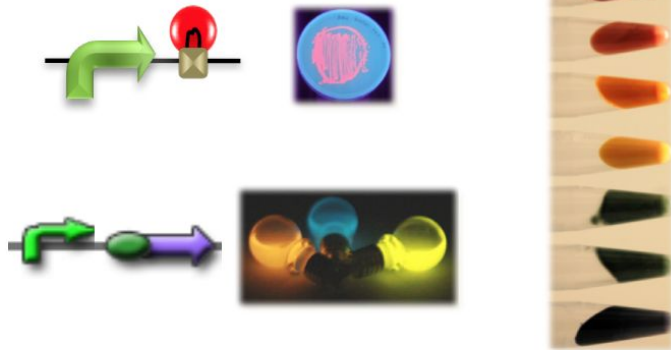

## Interface with cell & environment

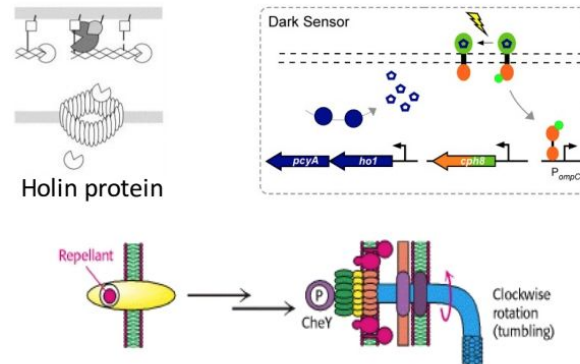



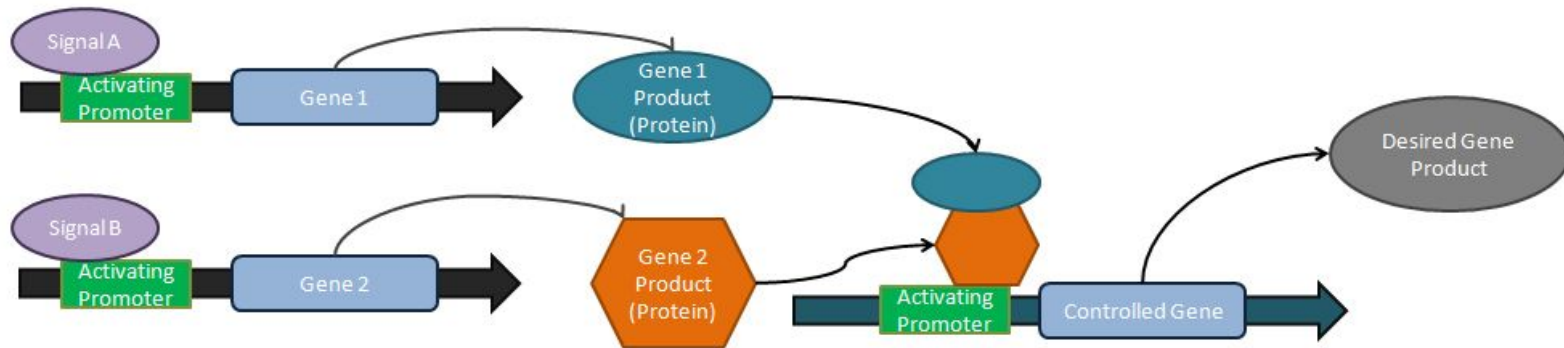
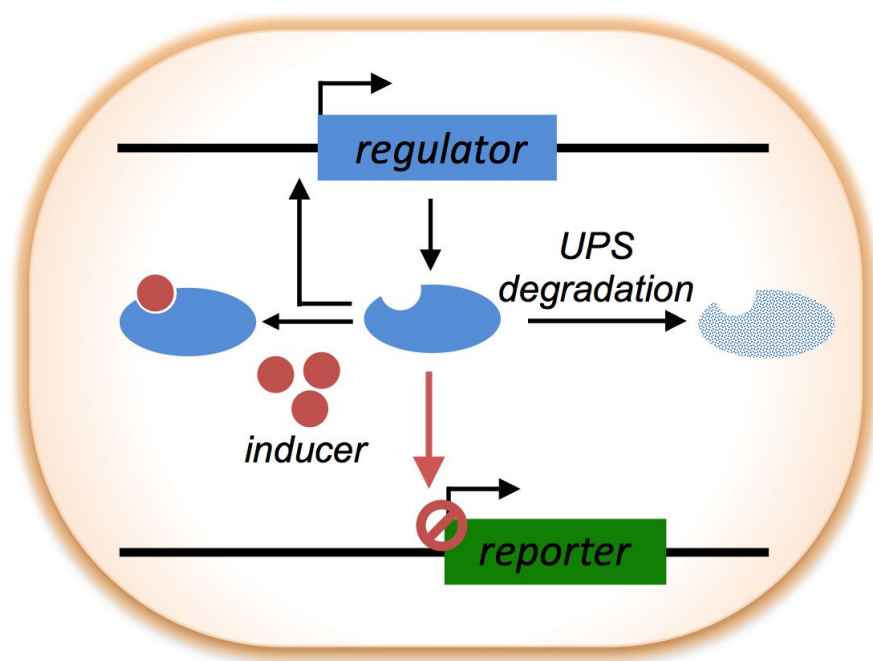

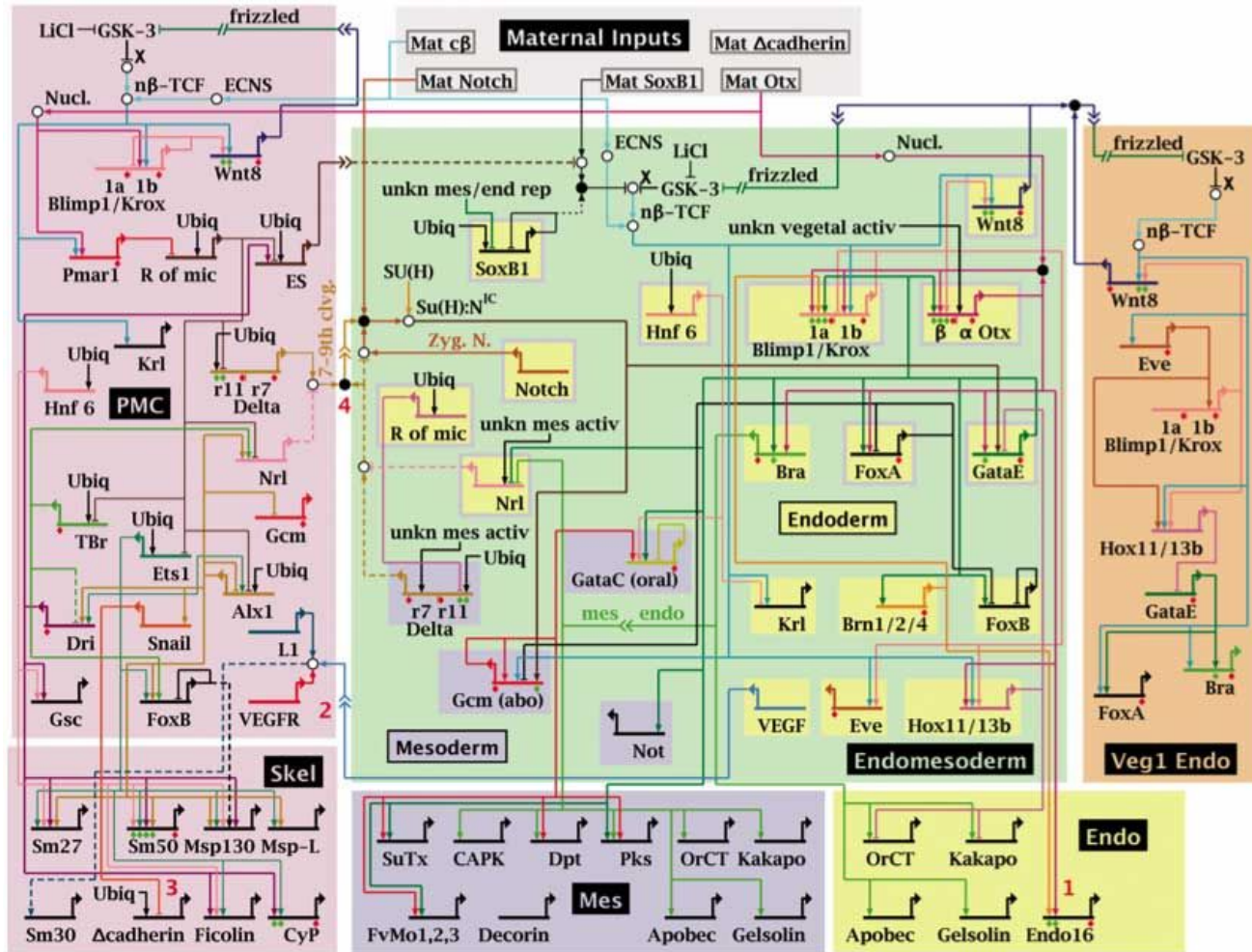

Ubiqu=ubiquitous; Mat = maternal; activ = activator; rep = repressor;  
 unkn = unknown; Nucl. = nuclearization;  $\chi$  =  $\beta$ -catenin source;  
 n $\beta$ -TCF = nuclearized b- $\beta$ -catenin-Tcf1; ES = early signal;  
 ECNS = early cytoplasmic nuclearization system; Zyg. N. = zygotic Notch

Copyright © 2001-2006 Hamid Bolouri and Eric Davidson



